

ENCLOSED TRACK SYSTEMS TRACK MAINTENANCE

ENCLOSED TRACK MAINTENANCE EQUIPMENT

Proper maintenance must be performed regularly to keep your system operating smoothly and to maintain workplace safety. Spanco offers a range of products to make your required track and trolley maintenance easier.

Spanco Enclosed Track Maintenance Trolleys

offer a quick and easy way to clean the enclosed track on your Spanco system. The trolley can be inserted into the end of runways and bridges to run along the bottom flange of the enclosed track. As the trolley moves along the track, the attached wire brushes remove built-up dirt and debris.



724MT

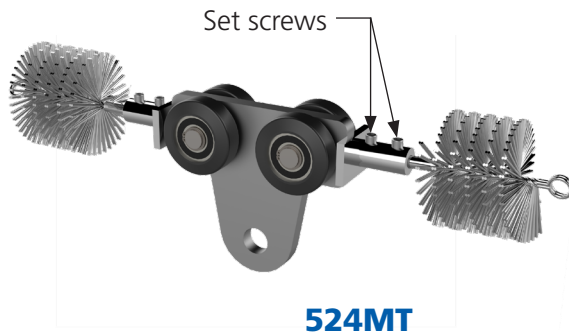

524MT

Spanco Maintenance Trolleys

are fabricated from a precision-cut steel plate. Maintenance Trolleys travel on quiet, long-lasting, large diameter, polyamide wheels equipped with anti-friction ball bearings. Part number 524MT is available for all 500-Series track, and part number 724MT is available for all 700-Series Track.

Maintenance Track Drop-Out

designs are available on a custom basis. Drop-out sections allow systems to be installed wall-to-wall for maximum coverage in a work area. Trolleys and end trucks can be inserted and removed from your entire overhead crane system at drop-out section locations along enclosed track bridges or runways. This design makes end truck, trolley, bridge, and runway maintenance possible without disassembling your overhead crane system.

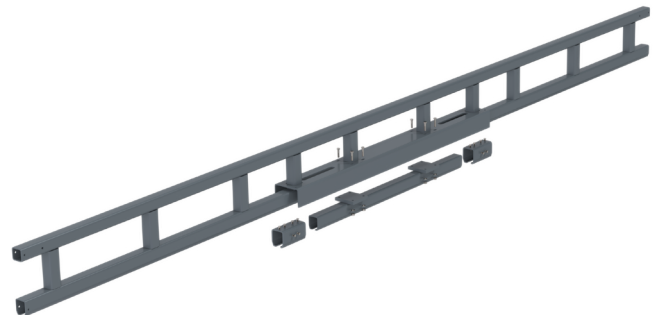

All maintenance track drop-out sections are made-to-order and customized to the customer's specific needs.