

WOOD-BEAM HANGER MANUAL ADDENDUM

Ceiling-Mounted Wood-Beam Hanger

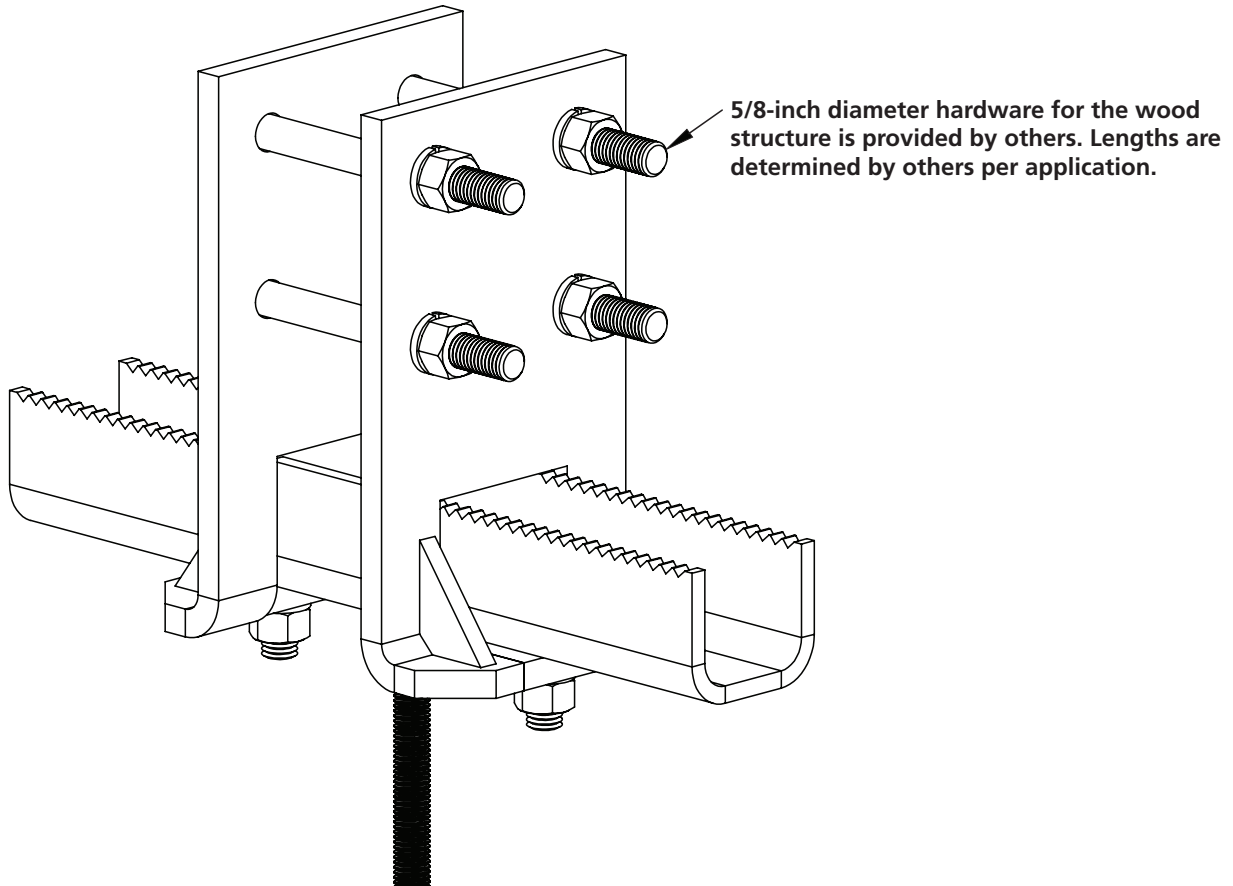

NOTE: This manual addendum must be read first and used in conjunction with manual 103-0010.

The use of this wood-beam hanger requires drilling holes through a wood beam commonly used in a building structure. Spanco requires the customer to have a local professional engineer certify that the strength of the wood beam after the holes are drilled is both in compliance with local codes and ordinances and can support both the original load and the additional hanger loads from the system. To assist with this required certification, Spanco provides the Wood-Beam Hanger Request for Quote Disclaimer during the selling process. You must take all appropriate steps to make sure that you indicate that your application meets or will meet all of the requirements on the Wood-Beam Hanger Request for Quote Disclaimer before using the system. Spanco cannot be held liable for any damage or injury resulting from the incorrect evaluation of the building requirements by the customer. A copy of the Wood-Beam Hanger Request for Quote Disclaimer requirements are below. Make sure that the wood-beam hanger is installed per the requirements in this addendum and manual 103-0010.

Requirements for Quote

- The calculations which verify that the customer’s support structure is sufficiently strong enough to resist all applied loads are provided by others.
- A local professional engineer hired by the customer must certify that the strength of the wood beam after the holes are drilled is in compliance with local codes and ordinances.
- A local professional engineer hired by the customer must certify that the strength of the wood beam after the holes are drilled can support both the original load and the additional hanger loads from the system.
- The local professional engineer’s certification should be retained in the customer’s records.
- The engineering of any customer-provided custom hanger design, hanger arrangement, and hanger welding, if applicable, is to be provided by others. Determination of wood strength is to be provided by others.
- The steel portion of the wood-beam hanger has a maximum loading of 6,000 pounds for 5/8-inch diameter drop rods and 6,000 pounds for 3/4-inch diameter drop rods.

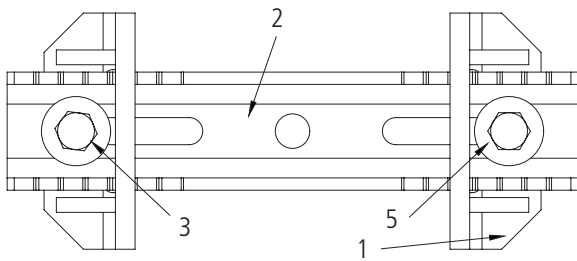

NOTE: Item 2 is part number 9-1285 for 5/8-inch diameter drop rods and 9-1568 for 3/4-inch diameter drop rods.

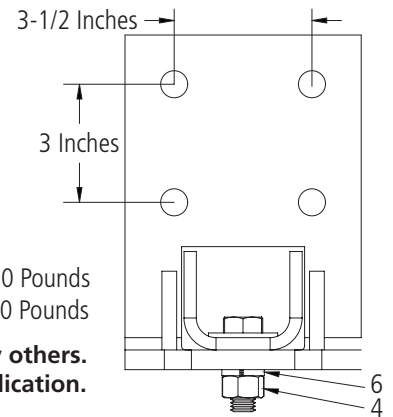

NOTE: 5/8-Inch Diameter Drop Rod Max. Loading—6,000 Pounds
 3/4-Inch Diameter Drop Rod Max. Loading—6,000 Pounds

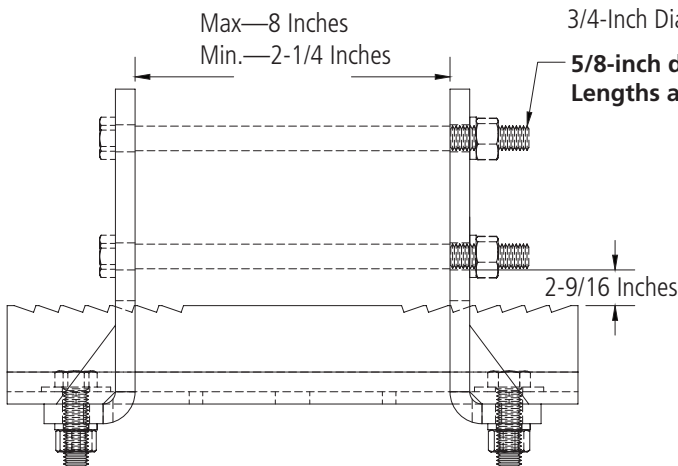

5/8-inch diameter hardware is provided by others. Lengths are determined by others per application.

Item	Part Number	Description
1	9-5242	Wood-Beam Hanger Weldment
2	9-1XXX	Beam Clamp Channel
3	10-0301	5/8-Inch by 2-Inch Hex Head Bolt
4	11-0040	5/8-Inch Hex Nut
5	15-0004	5/8-Inch Flat Washer
6	14-0004	5/8-Inch Split Lock Washer

NOTE: The information contained on this page is the sole property of Spanco. Any reproduction in part or whole without the written permission of Spanco is prohibited. Contact a Technical Sales Support Specialist for information about dual clamp arrangements because they require special considerations.

1. Wood-Beam Hanger for Plain Track

Refer to Figure 1 on page 5 and All Instructions in Manual 103-0010 for Steps A Through AL

- a) Ensure that track splices, if supplied, have been installed per **SPLICE INSTALLATION** in manual 103-0010.
- b) Using a measuring tape and a permanent marker, measure and mark your overhang requirements specified on your Final Fabrication Drawing on each end of the track. Also measure and mark your support spacing requirements specified on your Final Fabrication Drawing on the entire track. These locations are where the hanger kits should be installed on the track.
- c) Per **Figure 1**, slide all of the hanger brackets (8) onto the track so that the welded top square on the hanger bracket (8) is facing up away from the track.
- d) Per **Figure 1**, slide an end hanger bracket (8) onto the marked spot on the track so that the welded top square on the hanger bracket (8) is facing up away from the track.
- e) Per **Figure 1**, **securely tighten** the side set screw to align the track against the side of the hanger bracket (8). Do not overtighten the set screw.

NOTE: The hanger bracket (8) comes with a set screw threaded into the side. It doesn't matter which side. However, ensure that each hanger bracket (8) has the set screw threaded into the same side.

- f) Per **Figure 1**, screw a nut (6) onto the bottom of the threaded drop rod (7) and adjust so that about three inches of the drop rod (7) are showing from the bottom of the nut (6).
- g) Per **Figure 1**, slide a lock washer (5) onto the threaded drop rod (7) so that the lock washer (5) is underneath the nut (6).
- h) Per **Figure 1**, insert the bottom of the threaded drop rod (7) into the hole on the welded top square of the hanger bracket (8) until the lock washer (5) is flush against the top of the welded top square of the hanger bracket (8) and the nut (6) is flush against the lock washer (5).
- i) Per **Figure 1**, slide a lock washer (5) onto the threaded drop rod (7) so that the lock washer (5) is underneath the welded top square of the hanger bracket (8).
- j) Per **Figure 1**, **securely tighten** a nut (6) to the bottom of the threaded drop rod (7) so that the lock washer (5) is between the bottom of the welded top square of the hanger bracket (8) and the top of the nut (6) and adjust so that an inch of drop rod (7) is showing underneath the nut (6).
- k) Per **Figure 1**, screw a nut (6) onto the top of the threaded drop rod (7) and adjust so that about three inches of the drop rod (7) are showing from the top of the nut (6).
- l) Repeat steps **d)** through **k)** to attach all hanger brackets (8 in *Figure 1*) to the marked spots on the track.
- m) Use a man lift or cherry picker to reach the wood structure to measure its thickness.
- n) Per **Figure 1**, slide the wood-beam hanger weldment (1) on the beam clamp channel (2) using the measurement from step **m)** so that the drop-rod hole in the beam clamp channel (2) will be in the center of the wood structure.
- o) Per **Figure 1**, insert a bolt (3) through a flat washer (4), the slot in the beam clamp channel (2), and the hole in the wood-beam hanger weldment (1) so that the flat washer (4) is underneath the bolt head and on top of the slot in the beam clamp channel (2).
- p) Per **Figure 1**, slide a lock washer (5) onto the bolt (3) so that the lock washer (5) is underneath the wood-beam hanger weldment (1).
- q) Per **Figure 1**, **securely tighten** a nut (6) to the bolt (3).
- r) Repeat steps **o)** through **q)** to attach the remaining wood-beam hanger weldment (1 in *Figure 1*) to the beam clamp channel (2 in *Figure 1*).

- s) Repeat steps **n)** through **r)** to attach all wood-beam hanger weldments (1 in *Figure 1*) to the beam clamp channels (2 in *Figure 1*).
 - t) Measure the distance between the hole centers on the wood-beam hanger weldments (1 in *Figure 1*).
 - u) Use a man lift or cherry picker to reach the wood structure.
 - v) Using a permanent marker, mark the hole center locations on the wood structure using the measurements from step **t)**.
 - w) A local professional engineer hired by the customer must certify that the strength of the wood beam after the holes are drilled is in compliance with local codes and ordinances and can support both the original load and the additional hanger loads from the system. After this certification has been obtained, drill four holes into the wood structure.
 - x) Repeat steps **u)** through **w)** to drill the holes for each hanger assembly.
 - y) Per **Figure 1**, slide a lock washer (5) onto the threaded drop rod (7) so that the lock washer (5) is on top of the nut (6).
 - z) Per **Figure 1**, insert the top of the drop rod (7) through the drop-rod hole in the beam clamp channel (2) so that the lock washer (5) is flush against the bottom of the beam clamp channel (2).
 - aa) Per **Figure 1**, slide a lock washer (5) onto the threaded drop rod (7) so that the lock washer (5) is on top of the beam clamp channel (2).
 - ab) Per **Figure 1**, **securely tighten** a nut (6) to the top of the threaded drop rod (7) so that the lock washer (5) is between the top of the beam clamp channel (2) and the nut (6) and adjust so that an inch of drop rod (7) is showing on top of the nut (6).
 - ac) Repeat steps **y)** through **ab)** to attach the remaining beam clamp channels (2 in *Figure 1*) to the top of the drop rods (7 in *Figure 1*).
 - ad) Using a crane and lifting straps, lift the track to the existing wood structure.
 - ae) Use a man lift or cherry picker to reach the track and wood structure.
 - af) Per **Figure 1**, position the track and attached components (1 through 8) so that the wood-beam hanger weldments (1) are on either side of the wood structure.
- NOTE:** Track splice joints must be within one-foot from the center of where the wood-beam hanger weldments (1 in *Figure 1*) and beam clamp channel (2 in *Figure 1*) connect to the wood structure.
- ag) Per **Figure 1**, align the holes in the wood-beam hanger weldments (1) with the drilled holes in the wood structure.
 - ah) Per **Figure 1**, insert 5/8-inch diameter bolts provided by others through the aligned holes in the wood-beam hanger weldments (1) and the wood structure.
 - ai) Per **Figure 1**, **securely tighten** all 5/8-inch diameter hardware provided by others to the 5/8-inch diameter bolt provided by others.
 - aj) Repeat steps **ad)** through **ai)** to attach the track to the remaining wood structures.
 - ak) Repeat steps **a)** through **aj)** to attach the remaining tracks to the wood structures.
 - al) After all track has been **securely tightened** to all wood structures, torque all 5/8-inch diameter hex nuts to 154 foot-pounds. If supplied, torque all 3/4-inch diameter hex nuts to 257 foot-pounds.

Figure 1

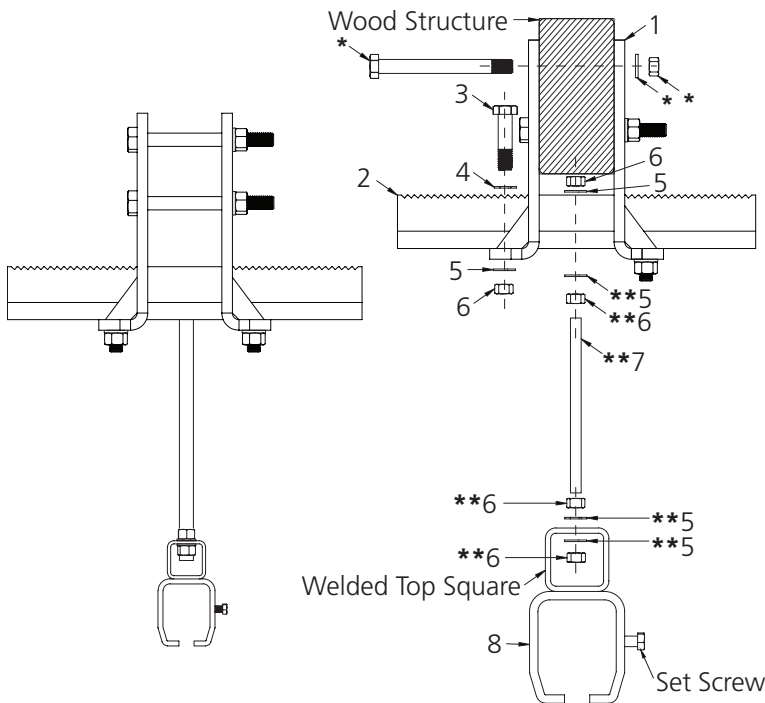

Item	Description
1	Wood-Beam Hanger Weldment
2	Beam Clamp Channel
3	5/8-Inch Dia. by 2-Inch Hex Head Bolt
4	5/8-Inch Dia. Flat Washer
5	5/8-Inch Dia. Lock Washer
6	5/8-Inch Dia. Hex Nut
7	5/8-Inch Dia. Drop Rod
8	Hanger Bracket

***NOTE:** 5/8-inch diameter hardware for the wood structure is provided by others. Lengths are determined by others per application.

****NOTE:** 700 Series track uses 3/4-inch diameter drop rod and hardware. Torque 5/8-inch diameter hardware to 154 foot-pounds and all 3/4-inch diameter hardware to 257 foot-pounds.

2. Wood-Beam Hanger for Trussed Track

Refer to Figure 2 on page 7 and All Instructions in Manual 103-0010 for Steps A Through AO

- a) Ensure that track splices, if supplied, have been installed per **SPLICE INSTALLATION** in manual 103-0010.
- b) Using a measuring tape and a permanent marker, measure and mark your overhang requirements specified on your Final Fabrication Drawing on each end of the track. Also measure and mark your support spacing requirements specified on your Final Fabrication Drawing on the entire track. These locations are where the hanger kits should be installed on the track.
- c) Per **Figure 2**, insert two bolts (9) through two flat washers (11) and the bottom slots of the hanger truss bracket (8) so that the flat washers (11) are between the bolt heads and the bottom of the hanger truss bracket (8).
- d) Per **Figure 2**, place the hanger truss bracket (8) on the marked spot on the end of the track so that the bolts (9) hang down on both sides of the track.
- e) Per **Figure 2**, align the slots in the angle truss clamp (10) with the bolts (9) and slide the angle truss clamp (10) on the bolts (9) until the angle truss clamp (10) is flush against the track. Ensure that the angle truss clamps (10) form *inverted-L's*.
- f) Per **Figure 2**, slide flat washers (11) on the bolts (9) until they are flush against the bottom of the angle truss clamp (10).
- g) Per **Figure 2**, slide lock washers (12) on the bolts (9) until they are flush against the bottom of the flat washers (11).
- h) Per **Figure 2**, **securely tighten** nuts (13) to the bolts (9) until the nuts (13) are flush against the bottom of the lock washers (12).
- i) Per **Figure 2**, screw a nut (6) onto the bottom of the threaded drop rod (7) so that about three inches of the drop rod (7) are showing from the bottom of the nut (6).
- j) Per **Figure 2**, slide a lock washer (5) onto the threaded drop rod (7) so that the lock washer (5) is underneath the nut (6).

- k) Per **Figure 2**, insert the bottom of the threaded drop rod (7) into the top hole of the hanger truss bracket (8) until the lock washer (5) is flush against the top of the hanger truss bracket (8) and the nut (6) is flush against the lock washer (5).
- l) Per **Figure 2**, slide a lock washer (5) onto the threaded drop rod (7) so that the lock washer (5) is underneath the top hole of the hanger truss bracket (8).
- m) Per **Figure 2**, **securely tighten** a nut (6) to the bottom of the threaded drop rod (7) so that the lock washer (5) is between the bottom of the top hole of the hanger truss bracket (8) and the top of the nut (6) and adjust so that an inch of drop rod (7) is showing underneath the nut (6).
- n) Per **Figure 2**, screw a nut (6) onto the top of the threaded drop rod (7) and adjust so that about three inches of the drop rod (7) are showing from the top of the nut (6).
- o) Repeat steps c) through n) to attach all hanger truss brackets (8 in *Figure 2*) to the marked spots on the track.
- p) Use a man lift or cherry picker to reach the wood structure to measure its thickness.
- q) Per **Figure 2**, slide the wood-beam hanger weldment (1) on the beam clamp channel (2) using the measurement from step p) so that the drop-rod hole in the beam clamp channel (2) will be in the center of the wood structure.
- r) Per **Figure 2**, insert a bolt (3) through a flat washer (4), the slot in the beam clamp channel (2), and the hole in the wood-beam hanger weldment (1) so that the flat washer (4) is underneath the bolt head and on top of the slot in the beam clamp channel (2).
- s) Per **Figure 2**, slide a lock washer (5) onto the bolt (3) so that the lock washer (5) is underneath the wood-beam hanger weldment (1).
- t) Per **Figure 2**, **securely tighten** a nut (6) to the bolt (3).
- u) Repeat steps r) through t) to attach the remaining wood-beam hanger weldment (1 in *Figure 2*) to the beam clamp channel (2 in *Figure 2*).
- v) Repeat steps q) through u) to attach all wood-beam hanger weldments (1 in *Figure 2*) to the beam clamp channels (2 in *Figure 2*).
- w) Measure the distance between the hole centers on the wood-beam hanger weldments (1 in *Figure 2*).
- x) Use a man lift or cherry picker to reach the wood structure.
- y) Using a permanent marker, mark the hole center locations on the wood structure using the measurements from step w).
- z) A local professional engineer hired by the customer must certify that the strength of the wood beam after the holes are drilled is in compliance with local codes and ordinances and can support both the original load and the additional hanger loads from the system. After this certification has been obtained, drill four holes into the wood structure.
- aa) Repeat steps x) through z) to drill the holes for each hanger assembly.
- ab) Per **Figure 2**, slide a lock washer (5) onto the threaded drop rod (7) so that the lock washer (5) is on top of the nut (6).
- ac) Per **Figure 2**, insert the top of the drop rod (7) through the drop-rod hole in the beam clamp channel (2) so that the lock washer (5) is flush against the bottom of the beam clamp channel (2).
- ad) Per **Figure 2**, slide a lock washer (5) onto the threaded drop rod (7) so that the lock washer (5) is on top of the beam clamp channel (2).
- ae) Per **Figure 2**, **securely tighten** a nut (6) to the top of the threaded drop rod (7) so that the lock washer (5) is between the top of the beam clamp channel (2) and the nut (6) and adjust so that an inch of drop rod (7) is showing on top of the nut (6).

- af) Repeat steps ab) through ae) to attach the remaining beam clamp channels (2 in Figure 2) to the top of the drop rods (7 in Figure 2).
 - ag) Using a crane and lifting straps, lift the track to the existing wood structure.
 - ah) Use a man lift or cherry picker to reach the track and wood structure.
 - ai) Per Figure 2, position the track and attached components (1 through 13) so that the wood-beam hanger weldments (1) are on either side of the wood structure.
- NOTE:** Track splice joints must be within four feet from the center of where the wood-beam hanger weldments (1 in Figure 2) and beam clamp channel (2 in Figure 2) connect to the wood structure.
- aj) Per Figure 2, align the holes in the wood-beam hanger weldments (1) with the drilled holes in the wood structure.
 - ak) Per Figure 2, insert 5/8-inch diameter bolts provided by others through the aligned holes in the wood-beam hanger weldments (1) and the wood structure.
 - al) Per Figure 2, **securely tighten** all 5/8-inch diameter hardware provided by others to the 5/8-inch diameter bolt provided by others.
 - am) Repeat steps ag) through al) to attach the track to the remaining wood structures.
 - an) Repeat steps a) through am) to attach the remaining tracks to the wood structures.
 - ao) After all track has been **securely tightened** to all wood structures, torque all 5/8-inch diameter hex nuts to 154 foot-pounds. If supplied, torque all 1/2-inch diameter hex nuts to 78 foot-pounds and all 3/4-inch diameter hex nuts to 257 foot-pounds.

Figure 2

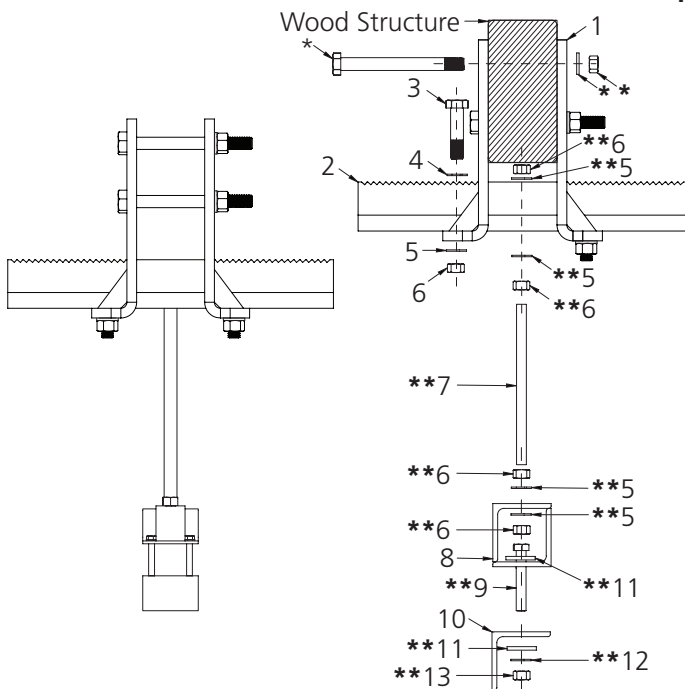

Item	Description
1	Wood-Beam Hanger Weldment
2	Beam Clamp Channel
3	5/8-Inch Dia. by 2-Inch Hex Head Bolt
4	5/8-Inch Dia. Flat Washer
5	5/8-Inch Dia. Lock Washer
6	5/8-Inch Dia. Hex Nut
7	5/8-Inch Dia. Drop Rod
8	Hanger Truss Bracket
9	1/2-Inch Dia. Hex Head Bolt
10	Angle Truss Clamp
11	1/2-Inch Dia. Flat Washer
12	1/2-Inch Dia. Lock Washer
13	1/2-Inch Dia. Hex Nut

****NOTE:** 1/2-inch diameter hardware above can be 5/8-inch diameter depending on the track series. 700 and 900 Series track use 3/4-inch diameter drop rod and hardware. Torque 1/2-inch diameter hardware to 78 foot-pounds, 5/8-inch diameter hardware to 154 foot-pounds, and all 3/4-inch diameter hardware to 257 foot-pounds.

***NOTE:** 5/8-inch diameter hardware for the wood structure is provided by others. Lengths are determined by others per application.

ABOUT SPANCO[®]

Our Commitment

Spanco professionals are dedicated to designing and manufacturing a variety of material handling solutions that meet all applicable CMAA, ANSI, OSHA, and MMA guidelines and standards. Our team of engineers and industry experts combine many years of experience in the material handling industry to manufacture material handling solutions that are backed by the best warranty in the industry.

Spanco production facilities are certified under the ISO 9001:2015 Quality Management System to provide superior quality products. And every welder at Spanco is certified to handle steel (D1.1) and aluminum (D1.2) in accordance with the rigorous requirements and lab testing established by the American Welders Society (AWS).

Spanco professionals welcome challenging projects that require custom crane engineering. Spanco also offers hundreds of pre-engineered lifting solutions, including Workstation Bridge Cranes, Jib Cranes, Gantry Cranes, Monorails, and Tractor Drives.

Our Production:

All of our systems are designed and manufactured in the United States of America. We have production facilities in Las Vegas, Nevada, and at our headquarters in Morgantown, Pennsylvania.

