



Promise to Perform Industries, Inc.

Installation and Maintenance Manual for SPANCO® Freestanding Workstation Jib Cranes



TABLE OF CONTENTS

Forward.....	3
Mast Installation.....	3-5
Manual Rotation Stop Installation.....	6
Boom Installation.....	6-7
Hoist Trolley and End Stop Installation.....	8
Festoon Options.....	8-9
Hoist Installation.....	10
Warning, Safety, or Capacity Labels.....	10
Acceptance Test.....	11
Spare Parts.....	11
Bill of Materials.....	11
Maintenance.....	12
Dimensions.....	13-14
Warranty and Service Policy.....	16

FORWARD

This manual contains important information to help you install, operate, maintain, and service your new workstation jib crane. We recommend that you study its contents thoroughly before putting the jib into use. We also recommend that you obtain the latest issue of ANSI B30.11 Safety Standard for Monorails and Underhung Cranes and study its contents thoroughly. By practicing the recommended maintenance suggestions, with proper installation, and application of correct operating procedures, you will be assured maximum service from your jib crane.

The jibs described in this manual are intended for indoor service. Jib cranes used for outdoor service require special consideration.

Information in this manual is subject to change without notice.



THIS EQUIPMENT IS NOT, IN ANY WAY, DESIGNED FOR LIFTING, SUPPORTING, OR TRANSPORTING HUMANS.

MAST INSTALLATION

(Refer to Figure 1)

Note: There are several types of base plate leveling methods to be used.

1. No shims or grout on a level and true smooth concrete surface.
2. Using shims (by others) and grout, as required, to plumb the mast on an irregular concrete surface. (Be aware that the slightest deviation from level will be magnified by the height of the mast and will result in difficulty leveling the boom.)
3. A preset leveling plate (by others) and grout.
4. Using leveling nuts (by others) and grout, as required.

For purposes of this manual, we will describe **method four**, leveling nuts and grout. Other methods are similar and may require special attention to anchor bolt projection lengths, grout thickness, and other onsite variables. In all cases, the finished installation requires full contact of the base plate on the foundation. All anchor bolts shall have plate washers (with standard holes) of adequate thickness for oversized base plate holes, per AISC requirements. Along with plate washers, a standard washer shall be used on each anchor bolt.

MAST INSTALLATION continued...

IT IS SOLELY THE CUSTOMER'S RESPONSIBILITY TO PROVIDE THE PROPER FOUNDATION FOR THE JIB CRANE SO THERE SHOULD BE NO DEVIATION FROM THE RECOMMENDED FOUNDATION SIZE OR INSTALLATION RECOMMENDATIONS WITHOUT FIRST CONSULTING A QUALIFIED PROFESSIONAL.

1. After installing the recommended concrete (3,000 PSI) foundation, reinforcement, and anchor bolts (minimum 1 inch diameter), refer to the dimension sheet of your specific model jib crane (**Pages 11-12 and Figures 1A or 1B and 2**).
2. Install one set of leveling nuts on the anchor bolts with the top surface approximately one inch above the foundation. Next, place the mast assembly over the anchor bolts resting on leveling nuts. Install the second set of nuts with plate washers and flat washers. Clamp the plumb fixture (a straight and rigid bar, level, or other custom made bracket) to mast cap plate and/or pivot pin. **Note: Fixture must be perpendicular to the mast.**
3. Select a position on the fixture arm, 2 inches from the edge of the mast, to hang a plumb line. Measure 60 inches down from the top of the mast and use this point to check the 2 inch dimension for mast plumb.
4. Position fixture arm directly over one anchor bolt and measure from the plumb line to the edge of the mast. If this measurement is not 2 inches, adjust the leveling nut directly below. Turn leveling nut up if greater than 2 inches, down if less than 2 inches.
5. Rotate the fixture arm 180 degrees and recheck mast for plumb. Adjust the leveling nuts until you have the same distance on each side of the mast. Repeat this operation at each anchor bolt or at 60 degree increments.
6. When mast is plumb tighten the locking nuts.

Note: Do not grout until installation of boom is complete.

7. When installation of crane is complete and the operation is double checked, float grouting compound under base plate and recheck tightness of locking nuts.

THE BOLT PADS ARE TAC WELDED TO BASE PLATE FOR EASY REMOVAL IN CASE OF SLIGHT MISALIGNMENT OF ANCHOR BOLT. GRIND TAC AREA TO REMOVE BOLT PAD OR PADS. RESET THE MAST UNIT OVER THE ANCHOR BOLTS AND LEVELING NUTS. BE SURE TO PUT THE BOLT PAD OR PADS BACK INTO PLACE BEFORE INSTALLING THE 2ND SET OF NUTS. THESE BOLT PADS DO NOT REQUIRE WELDING ONCE THEY ARE REMOVED AND REPLACED.

MAST INSTALLATION continued...

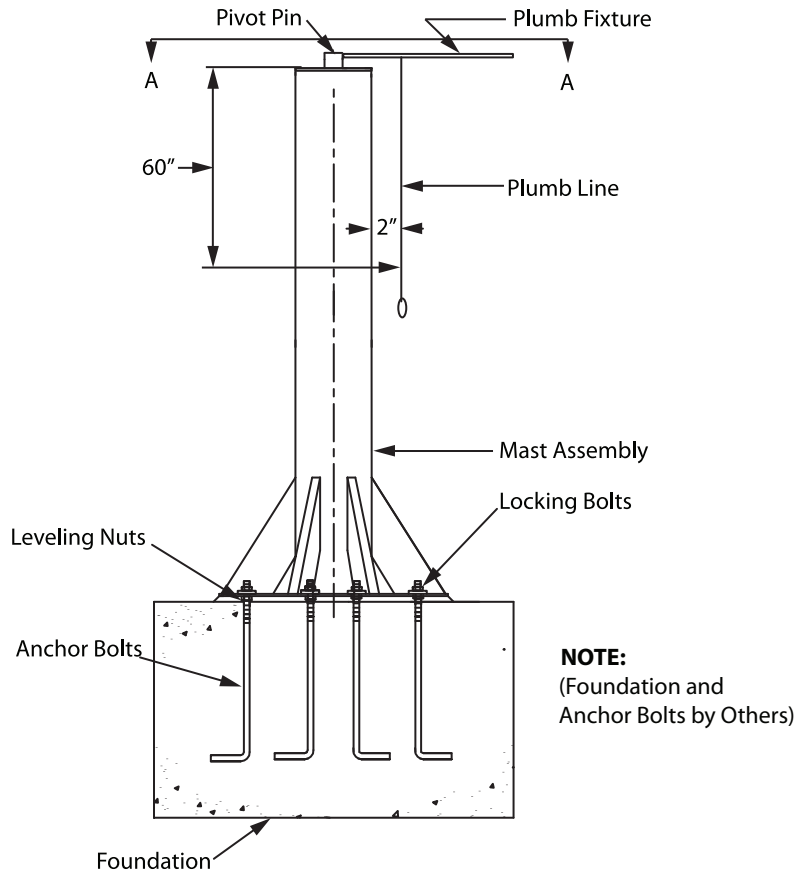

Figure 1

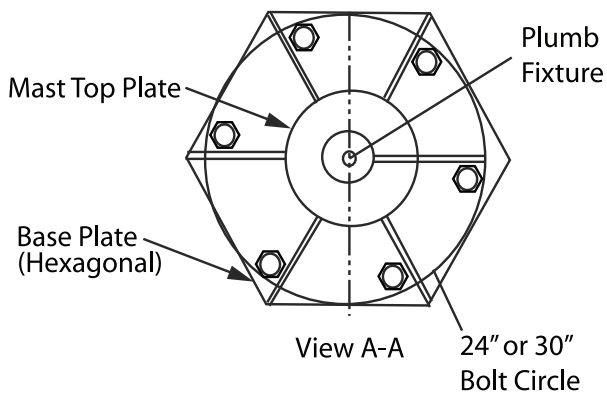

Figure 1A

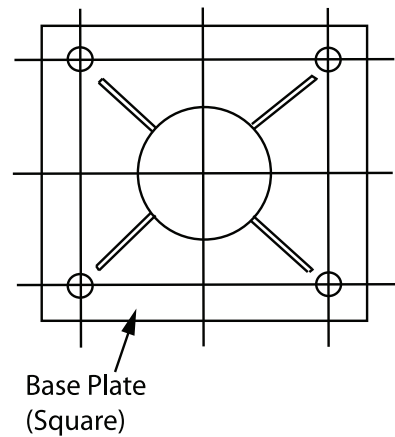
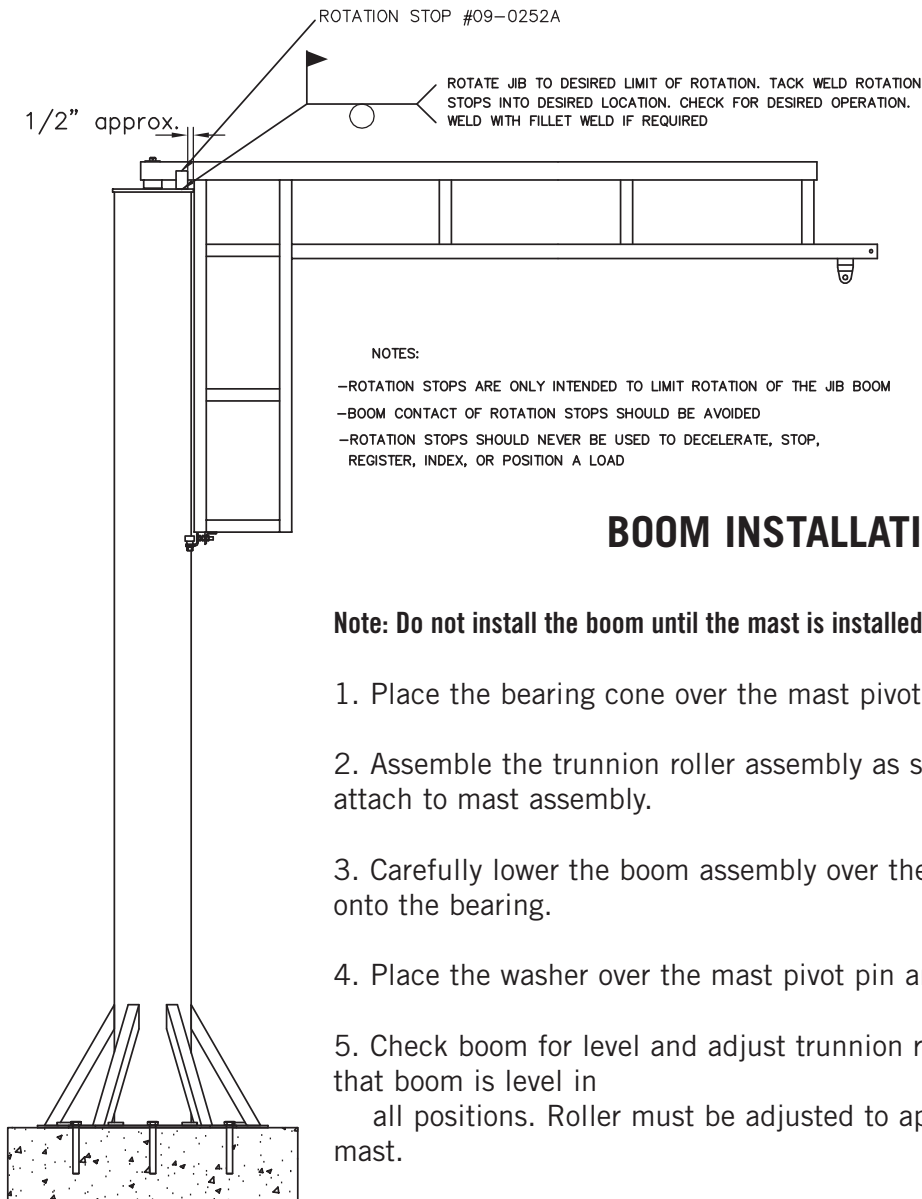

Figure 1B

ROTATION STOP INSTALLATION INSTRUCTION



BOOM INSTALLATION

Note: Do not install the boom until the mast is installed properly and plumbed.

1. Place the bearing cone over the mast pivot pin.
2. Assemble the trunnion roller assembly as shown in **Figure 2A** and attach to mast assembly.
3. Carefully lower the boom assembly over the mast pivot pin and onto the bearing.
4. Place the washer over the mast pivot pin and insert the cotter pin.
5. Check boom for level and adjust trunnion roller assembly to insure that boom is level in all positions. Roller must be adjusted to apply pressure to the mast.

NOTE: If boom and/or mast is not level, the trolley or boom will not stay in position when not in use.

Re-adjust mast or boom for plumb and level is required.

6. To compensate for anticipated deflection it may be necessary to adjust boom with the tip raised a distance equal to half the expected deflection. Each jib is designed for a maximum:

$$\text{Boom Length (inches)} \div 150 = \text{Deflection (inches)}$$

BOOM INSTALLATION continued...

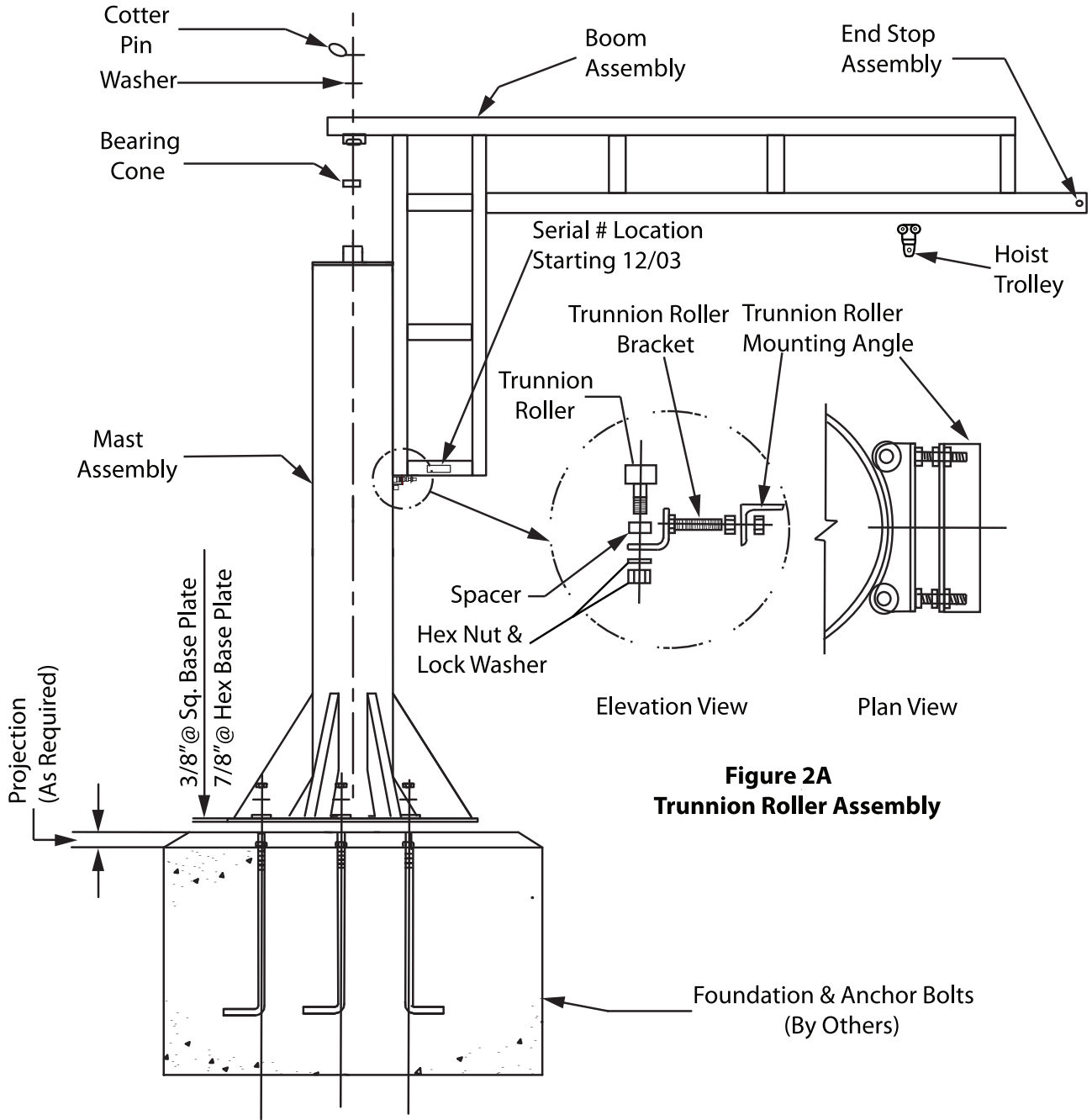

Figure 2A
Trunnion Roller Assembly

Figure 2

HOIST TROLLEY AND END-STOP INSTALLATION

(Refer to Figure 3)

Note: This procedure may differ depending upon the festoon option you choose (See Figures 5A, 5B, and 5C). Festoon cables and trolleys are optional.

1. Place end clamp, festoon trolleys, then hoist trolley on the boom track. (See Figure 3)
2. Secure the end stop bolts and rubber bumper.
3. Install the festoon cable on the festoon trolleys at equal spacing as required.

FESTOON OPTIONS

1. No festooning (Standard Cranes)
2. Flat cable festoon (Figure 5A)
3. Box track festoon (Figure 5B)
4. Air festoon (Figure 5C)
5. 360 degree collector (Figure 6)
6. 360 degree air swivel (Figure 7)

Figure 3
BOOM FESTOON DETAIL

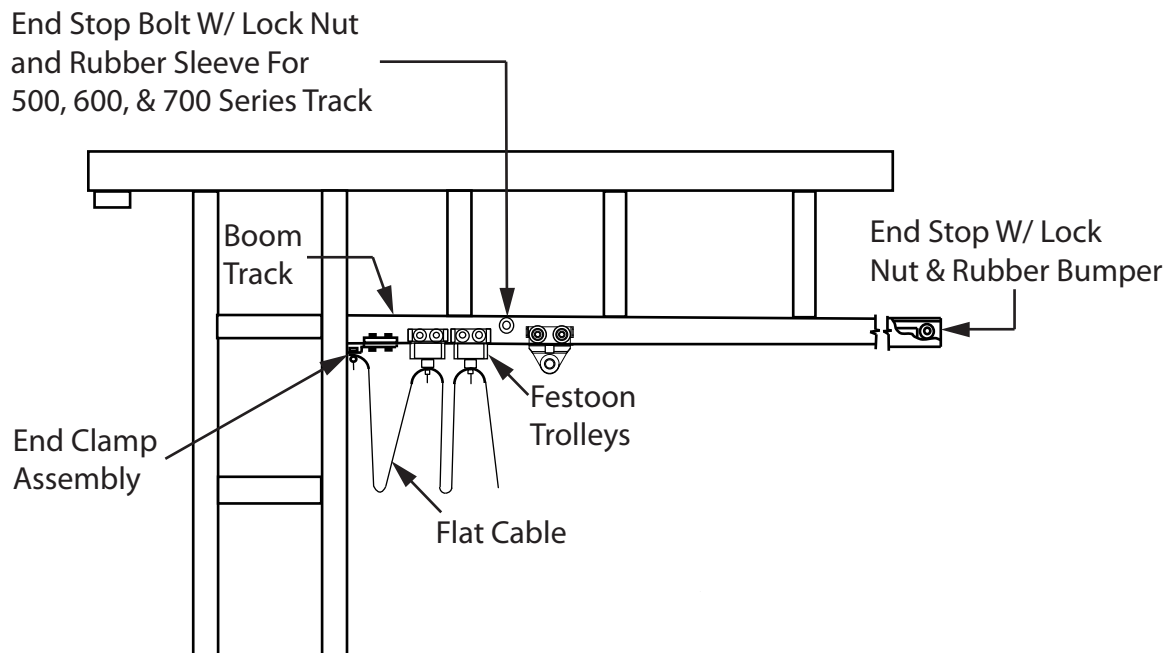

FESTOON OPTIONS continued...

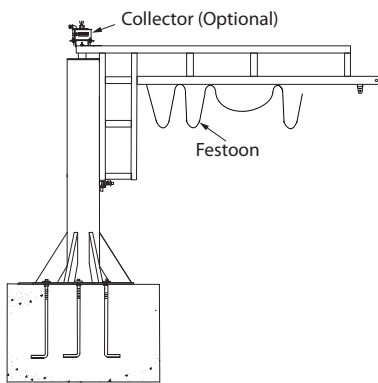

Figure 5A
Festoon Option

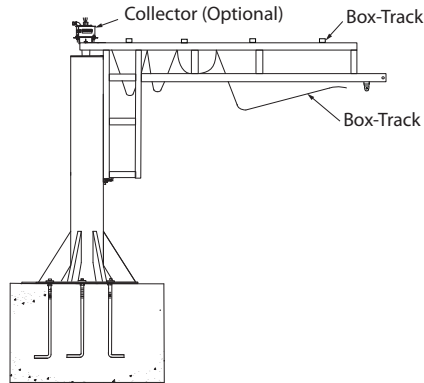

Figure 5B
Box-Track Option

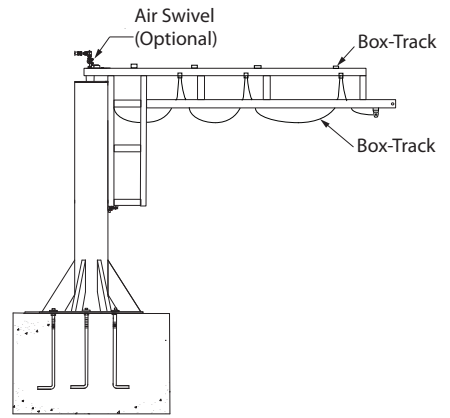

Figure 5C
Air Festoon Option

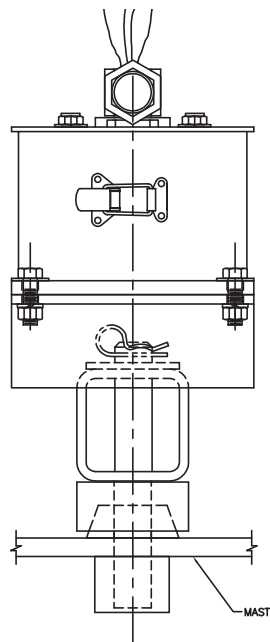

Figure 6
Collector Detail

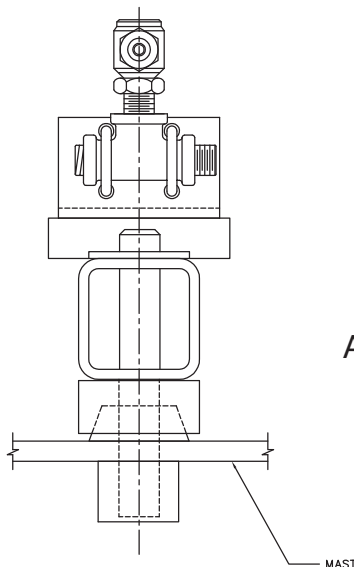
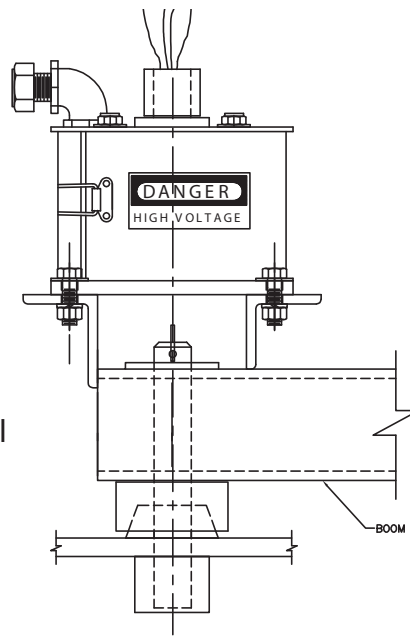
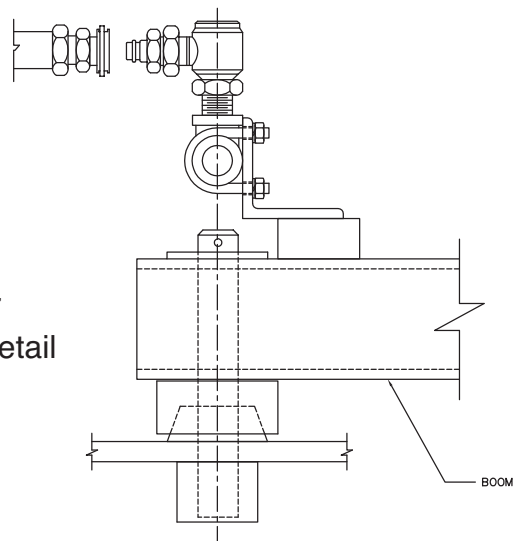

Figure 7
Air Swivel Detail



HOIST INSTALLATION

1. Attach hoist to hoist trolley.
2. Use washers on hoist mounting pin to center inside the hoist trolley.
3. Reinstall washer on the outside of the hoist trolley (both sides) before installing or reinstalling cotter pins to secure hoist mounting pin. Replace cotter pin(s) if worn or broken.
4. Bend cotter pin around mounting pin.
5. Recheck for plumb and level. Adjust as necessary.
6. If your jib crane requires grout at the base plate, it shall be grouted at this time.

▲ WARNING DO NOT OPERATE HOIST OR CRANE IF COTTER PINS ARE NOT IN PLACE AND PROPERLY BENT OVER ON BOTH SIDES OF THE HOIST TROLLEY. CHECK REGULARLY THAT THE COTTER PINS ARE IN PLACE AND SECURING THE HOIST ON THE HOIST TROLLEY.

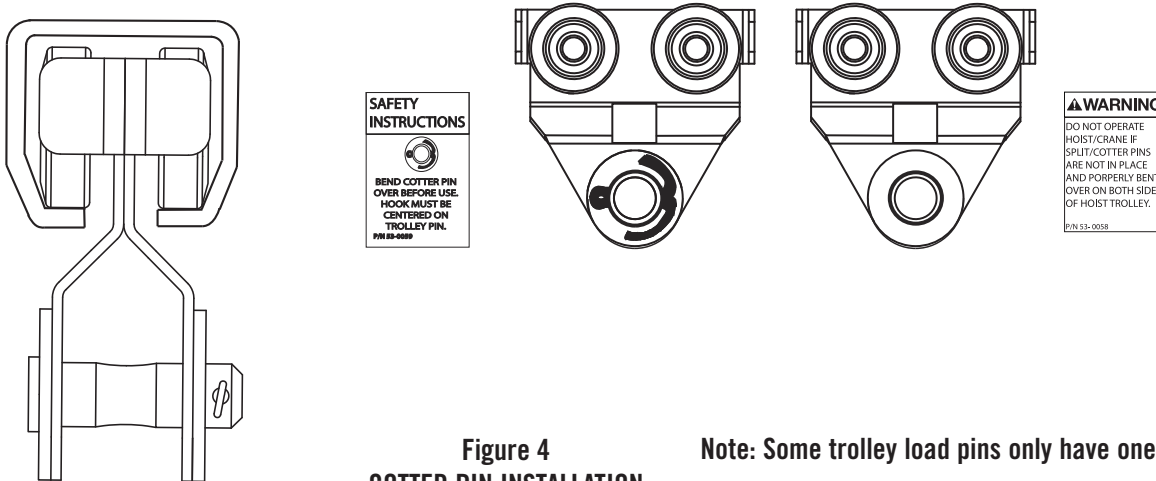

Figure 4
COTTER PIN INSTALLATION

Note: Some trolley load pins only have one cotter pin.

WARNING, SAFETY, OR CAPACITY LABELS

If at any time these labels are lost, stolen, removed, or become illegible, contact SPANCO at 800-869-2080 for free replacements. Please order by part number on the label.

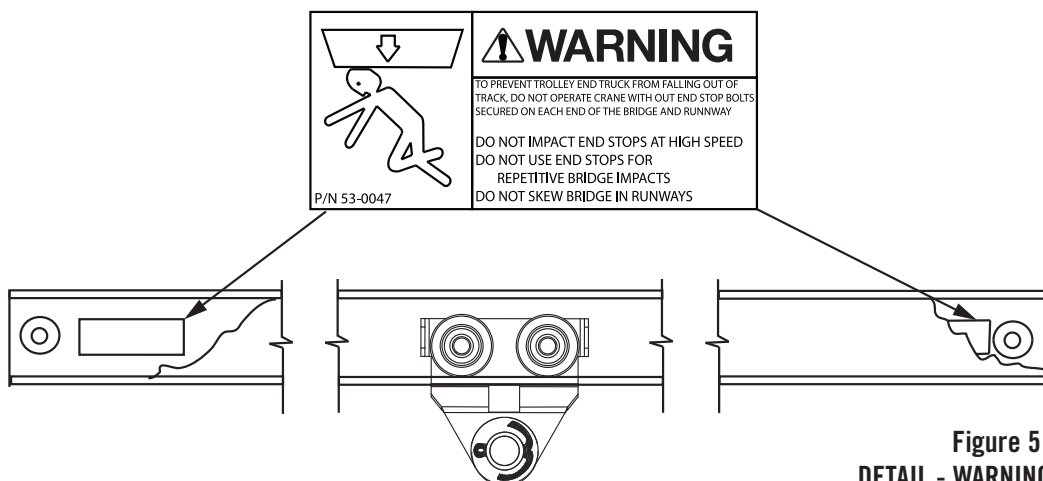

Figure 5
DETAIL - WARNING LABELS

ACCEPTANCE TEST

After the jib crane has been installed, OSHA requires an acceptance test before operating and also after any modifications. This acceptance test should be performed by an authorized dealer or installer.

SPARE PARTS

The following standard bill of materials shall be used as a guide when receiving your workstation jib crane and when ordering spare parts. Items listed with an asterisk (*) are specific to your particular model number. Specify work order number, model number, and part number when ordering spare parts.

BILL OF MATERIALS

ITEM	QUANTITY	DESCRIPTION	PART NO.	REMARKS
1	1	BOOM ASSEMBLY	*	
2	1	END STOP ASSEMBLY	*	
3	1	FLAT WASHER	15-0007	
4	1	COTTER PIN	23-0003	
5	1	GREASE FITTING	25-0002	
6	1	BEARING CONE	50-0006	
7	2	TRUNNION ROLLER	42-0008	
8	2	HEX NUT	11-0050	
9	2	LOCK WASHER	14-0004	
10	1	TRUNNION ROLLER BRACKET	*	
11	4	HEX JAM NUT	12-0014	
12	1	HOIST TROLLEY	*	
13	1	MAST ASSEMBLY	*	
14	2	SPACER	06-0260	

MAINTENANCE

Once installation is complete the jib crane system should be checked thoroughly for tightness of nuts and bolts. In order to maintain efficient operating conditions, SPANCO recommends establishing a regular inspection and lubrication schedule. Inspection of all parts should be made. Loose parts should be adjusted and worn parts should be replaced immediately.

If a specific usage pattern cannot be determined, the crane operator or maintenance engineer should estimate when the crane should be lubricated. Generally, a jib crane operating 24 hours per day, seven days per week requires lubrication once a week. A jib crane operating eight hours per day, five days per week requires lubrication once every two to three weeks. A jib crane operating once or twice a month requires lubrication at least once every six months.

NOTE: The points requiring lubrication are the main pivot bearing.

RECOMMENDED LUBRICANTS:

NLGI No. 1 or No. 2 greases.

DIMENSIONS

100-150 LB CAPACITY

360° ROTATION

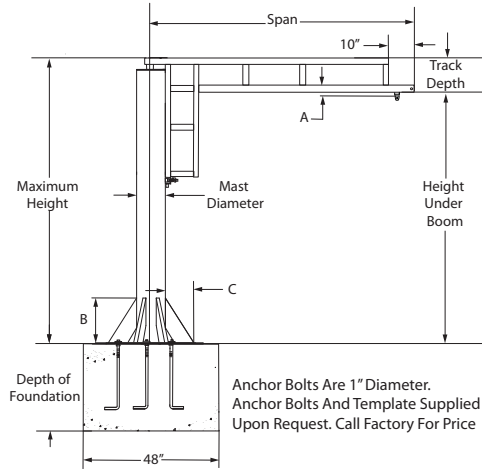

CAP. LB.	HEIGHT UNDER BOOM	MAX. HEIGHT FT.	SPAN FT.	MAST DIA. IN.	TRACK DEPTH IN.	A IN.	B IN.	C IN.	NO. OF BOLTS	BASE STYLE	ANCHOR BOLT LOAD LB.	DEPTH OF FOUNDATION IN.	WT. LB.	MODEL NO.
100	8	8'-5"	4	6 5/8	4 1/4	2 1/4	4	4	4	12"SQ	330	6	250	FR100-4-8
		8'-5"	6	6 5/8	4 1/4	2 1/4	4	4	4	12"SQ	595	6	265	FR100-6-8
		8'-9 3/4"	8	6 5/8	9	2 1/4	4	4	4	12"SQ	960	6	335	FR100-8-8
		8'-9 3/4"	10	6 5/8	9	2 1/4	4	4	4	12"SQ	1,055	6	350	FR100-10-8
		8'-11 3/4"	12	6 5/8	11	2 1/4	4	4	4	12"SQ	1,645	6	365	FR100-12-8
		8'-11 3/4"	14	6 5/8	11	2 1/4	4	4	4	12"SQ	2,055	6	405	FR100-14-8
	8'-11 3/4"	16	6 5/8	11	2 1/4	4	4	4	12"SQ	2,465	6	425	FR100-16-8	
	10	10'-5"	4	6 5/8	4 1/4	2 1/4	4	4	4	12"SQ	320	6	285	FR100-4-10
		10'-5"	6	6 5/8	4 1/4	2 1/4	4	4	4	12"SQ	585	6	300	FR100-6-10
		10'-9 3/4"	8	6 5/8	9	2 1/4	4	4	4	12"SQ	950	6	365	FR100-8-10
		10'-9 3/4"	10	6 5/8	9	2 1/4	4	4	4	12"SQ	1,050	6	375	FR100-10-10
		10'-11 3/4"	12	6 5/8	11	2 1/4	4	4	4	12"SQ	1,635	6	410	FR100-12-10
		10'-11 3/4"	14	6 5/8	11	2 1/4	4	4	4	12"SQ	1,905	6	430	FR100-14-10
	12	10'-11 3/4"	16	6 5/8	11	2 1/4	4	4	4	12"SQ	2,460	6	450	FR100-16-10
		12'-5"	4	6 5/8	4 1/4	2 1/4	4	4	4	12"SQ	310	6	325	FR100-4-12
		12'-5"	6	6 5/8	4 1/4	2 1/4	4	4	4	12"SQ	575	6	340	FR100-6-12
		12'-9 3/4"	8	6 5/8	9	2 1/4	4	4	4	12"SQ	940	6	405	FR100-8-12
		12'-9 3/4"	10	6 5/8	9	2 1/4	4	4	4	12"SQ	1,040	6	415	FR100-10-12
12'-11 3/4"		12	6 5/8	11	2 1/4	4	4	4	12"SQ	1,625	6	460	FR100-12-12	
150	8	12'-11 3/4"	14	6 5/8	11	2 1/4	4	4	4	12"SQ	2,035	6	480	FR100-14-12
		12'-11 3/4"	16	8 5/8	11	2 1/4	4	4	4	12"SQ	2,435	6	545	FR100-16-12
		8'-5"	4	6 5/8	4 1/4	2 1/4	4	4	4	12"SQ	510	6	250	FR150-4-8
		8'-5"	6	6 5/8	4 1/4	2 1/4	4	4	4	12"SQ	950	6	265	FR150-6-8
		8'-9 3/4"	8	6 5/8	9	2 1/4	4	4	4	12"SQ	1,355	6	335	FR150-8-8
		8'-9 3/4"	10	6 5/8	9	2 1/4	4	4	4	12"SQ	1,780	6	350	FR150-10-8
	10	8'-11 3/4"	12	6 5/8	11	2 1/4	4	4	4	12"SQ	2,260	6	365	FR150-12-8
		9'-3 1/8"	14	6 5/8	14 3/8	2 5/8	4	4	4	12"SQ	3,120	6	505	FR150-14-8
		9'-3 1/8"	16	8 5/8	14 3/8	2 5/8	2 1/2	2 1/2	4	12"SQ	3,750	6	590	FR150-16-8
		10'-5"	4	6 5/8	4 1/4	2 1/4	4	4	4	12"SQ	500	6	285	FR150-4-10
		10'-5"	6	6 5/8	4 1/4	2 1/4	4	4	4	12"SQ	950	6	300	FR150-6-10
		10'-9 3/4"	8	6 5/8	9	2 1/4	4	4	4	12"SQ	1,350	6	365	FR150-8-10
	12	10'-9 3/4"	10	6 5/8	9	2 1/4	4	4	4	12"SQ	1,775	6	375	FR150-10-10
		10'-11 3/4"	12	6 5/8	11	2 1/4	4	4	4	12"SQ	2,250	6	410	FR150-12-10
		11'-3 1/8"	14	6 5/8	14 3/8	2 5/8	4	4	4	12"SQ	3,130	6	450	FR150-14-10
		11'-3 1/8"	16	8 5/8	14 3/8	2 5/8	2 1/2	2 1/2	4	12"SQ	3,740	6	635	FR150-16-10
		12'-5"	4	6 5/8	4 1/4	2 1/4	4	4	4	12"SQ	490	6	325	FR150-4-12
		12'-5"	6	6 5/8	4 1/4	2 1/4	4	4	4	12"SQ	940	6	340	FR150-6-12
12	12'-9 3/4"	8	6 5/8	9	2 1/4	4	4	4	12"SQ	1,340	6	405	FR150-8-12	
	12'-9 3/4"	10	6 5/8	9	2 1/4	4	4	4	12"SQ	1,765	6	415	FR150-10-12	
	12'-11 3/4"	12	6 5/8	11	2 1/4	4	4	4	12"SQ	2,240	6	460	FR150-12-12	
	13'-3 1/8"	14	8 5/8	14 3/8	2 5/8	2 1/2	2 1/2	4	12"SQ	3,080	6	650	FR150-14-12	
	13'-3 1/8"	16	8 5/8	14 3/8	2 5/8	2 1/2	2 1/2	4	12"SQ	3,730	6	680	FR150-16-12	

DIMENSIONS continued...
250, 500, AND 1,000 LB CAPACITIES
360° ROTATION

CAP LB.	HT. UNDER BOOM	MAX HT. FT.	SPAN FT.	MAST DIA. IN.	TRACK DEPTH IN.	A IN.	B IN.	C IN.	NO. OF BOLTS	BASE STYLE	ANCHOR BOLT LOAD LB.	DEPTH OF FOUNDATION IN.	WT. LB.	MODEL NO.	
250	8	8'-5"	4	6 5/8	4 1/4	2 1/4	4	4	4	12"SQ	855	6	250	FR250-4-8	
		8'-9 3/4"	6	6 5/8	9	2 1/4	4	4	4	12"SQ	1,510	6	265	FR250-6-8	
		8'-9 3/4"	8	6 5/8	9	2 1/4	4	4	4	4	12"SQ	2,140	6	335	FR250-8-8
		8'-11 3/4"	10	6 5/8	11	2 1/4	4	4	4	4	12"SQ	2,705	6	350	FR250-10-8
		9'-3 1/8"	12	8 5/8	14 3/8	2 5/8	18 3/8	10 5/8	6	24"HEX	1,685	36	615	FR250-12-8	
		9'-3 1/8"	14	8 5/8	14 3/8	2 5/8	18 3/8	10 5/8	6	24"HEX	2,085	36	645	FR250-14-8	
	9'-3 1/8"	16	8 5/8	14 3/8	2 5/8	18 3/8	10 5/8	6	24"HEX	2,490	36	675	FR250-16-8		
	10	10'-5"	4	6 5/8	4 1/4	2 1/4	4	4	4	4	12"SQ	855	6	285	FR250-4-10
		10'-9 3/4"	6	6 5/8	4 1/4	2 1/4	4	4	4	4	12"SQ	1,510	6	350	FR250-6-10
		10'-9 3/4"	8	8 5/8	4 1/4	2 1/4	2 1/2	2 1/2	4	4	12"SQ	2,140	6	410	FR250-8-10
		10'-11 3/4"	10	8 5/8	4 1/4	2 1/4	2 1/2	2 1/2	4	4	12"SQ	2,705	6	425	FR250-10-10
		11'-3 1/8"	12	8 5/8	4 1/4	2 5/8	18 3/8	10 5/8	6	24"HEX	1,685	36	660	FR250-12-10	
		11'-3 1/8"	14	8 5/8	4 1/4	2 5/8	18 3/8	10 5/8	6	24"HEX	2,085	36	690	FR250-14-10	
		11'-3 1/8"	16	8 5/8	4 1/4	2 5/8	18 3/8	10 5/8	6	24"HEX	2,490	36	720	FR250-16-10	
		12'-5"	4	6 5/8	4 1/4	2 1/4	4	4	4	4	12"SQ	855	6	325	FR250-4-12
		12'-9 3/4"	6	6 5/8	4 1/4	2 1/4	4	4	4	4	12"SQ	1,510	6	385	FR250-6-12
		12'-9 3/4"	8	8 5/8	4 1/4	2 1/4	2 1/2	2 1/2	4	4	12"SQ	2,140	6	455	FR250-8-12
		12'-11 3/4"	10	8 5/8	4 1/4	2 1/4	2 1/2	2 1/2	4	4	12"SQ	2,705	6	480	FR250-10-12
		13'-3 1/8"	12	8 5/8	4 1/4	2 5/8	18 3/8	10 5/8	6	24"HEX	1,685	36	705	FR250-12-12	
	13'-3 1/8"	14	8 5/8	4 1/4	2 5/8	18 3/8	10 5/8	6	24"HEX	2,085	36	735	FR250-14-12		
	13'-3 1/8"	16	12 3/4	4 1/4	2 5/8	20	11 1/2	4	30"HEX	2,490	36	915	FR250-16-12		
	500	8	8'-10 3/4"	4	8 5/8	4 1/4	2 5/8	2 1/2	2 1/2	4	12"SQ	1,685	6	340	FR500-4-8
			8'-10 3/4"	6	8 5/8	4 1/4	2 5/8	2 1/2	2 1/2	6	12"SQ	2,590	6	370	FR500-6-8
			9'-1 1/8"	8	8 5/8	4 1/4	2 5/8	18 3/8	10 5/8	6	24"HEX	1,855	36	505	FR500-8-8
9'-1 1/8"			10	12 3/4	4 1/4	2 5/8	20	11 1/2	6	30"HEX	2,430	36	635	FR500-10-8	
9'-3 1/8"			12	12 3/4	4 1/4	2 5/8	20	11 1/2	6	30"HEX	3,070	48	710	FR500-12-8	
9'-5 3/4"			14	12 3/4	4 1/4	3 1/16	20	11 1/2	6	30"HEX	3,723	48	998	FR500-14-8	
9'-5 3/4"		16	12 3/4	4 1/4	3 1/16	20	11 1/2	4	30"HEX	4,561	48	1014	FR500-16-8		
10		10'-10 3/4"	4	8 5/8	4 1/4	2 5/8	2 1/2	2 1/2	4	4	12"SQ	1,685	6	380	FR500-4-10
		10'-10 3/4"	6	8 5/8	4 1/4	2 5/8	2 1/2	2 1/2	4	4	12"SQ	2,590	6	410	FR500-6-10
		11'-1 1/8"	8	8 5/8	4 1/4	2 5/8	18 3/8	10 5/8	6	24"HEX	1,855	36	550	FR500-8-10	
		11'-1 1/8"	10	12 3/4	4 1/4	2 5/8	20	11 1/2	6	30"HEX	2,430	36	635	FR500-10-10	
		11'-3 1/8"	12	12 3/4	4 1/4	2 5/8	20	11 1/2	6	30"HEX	3,070	36	790	FR500-12-10	
		11'-5 3/4"	14	12 3/4	4 1/4	3 1/16	20	11 1/2	6	30"HEX	3,723	48	1010	FR500-14-10	
		11'-5 3/4"	16	12 3/4	4 1/4	3 1/16	20	11 1/2	6	30"HEX	4,561	48	1090	FR500-16-10	
		12'-10 3/4"	4	8 5/8	4 1/4	2 5/8	2 1/2	2 1/2	4	4	12"SQ	1,685	6	430	FR500-4-12
		12'-10 3/4"	6	8 5/8	4 1/4	2 5/8	2 1/2	2 1/2	4	4	12"SQ	2,590	6	460	FR500-6-12
		13'-1 1/8"	8	12 3/4	4 1/4	2 5/8	20	11 1/2	6	30"HEX	1,855	36	745	FR500-8-12	
		13'-1 1/8"	10	12 3/4	4 1/4	2 5/8	20	11 1/2	6	30"HEX	2,430	36	770	FR500-10-12	
		13'-3 1/8"	12	12 3/4	4 1/4	2 5/8	20	11 1/2	6	30"HEX	3,070	36	855	FR500-12-12	
13'-5 3/4"		14	12 3/4	4 1/4	3 1/16	20	11 1/2	6	30"HEX	3,723	48	1030	FR500-14-12		
13'-5 3/4"		16	12 3/4	4 1/4	3 1/16	20	11 1/2	6	30"HEX	4,561	48	1115	FR500-16-12		
1,000		8	8'-11 3/4"	4	12 3/4	4 1/4	3 1/16	20	11 1/2	6	30"HEX	1,420	48	570	FR1000-4-8
			8'-11 3/4"	6	12 3/4	4 1/4	3 1/16	20	11 1/2	6	30"HEX	2,495	48	610	FR1000-6-8
			8'-11 3/4"	8	12 3/4	4 1/4	3 1/16	20	11 1/2	6	30"HEX	3,545	48	665	FR1000-8-8
	9'-2 1/8"		10	12 3/4	4 1/4	3 1/16	20	11 1/2	6	30"HEX	4,750	48	755	FR1000-10-8	
	9'-5 3/4"		12	12 3/4	4 1/4	3 1/16	20	11 1/2	6	30"HEX	5,935	48	835	FR1000-12-8	
	9'-8 3/4"		14	12 3/4	4 1/4	4 1/8	20	11 1/2	6	30"HEX	6,007	48	1008	FR1000-14-8	
	9'-8 3/4"	16	12 3/4	4 1/4	4 1/8	20	11 1/2	6	30"HEX	6,958	48	1096	FR1000-16-8		
	10	10'-11 3/4"	4	12 3/4	4 1/4	3 1/16	20	11 1/2	6	30"HEX	1,420	48	640	FR1000-4-10	
		10'-11 3/4"	6	12 3/4	4 1/4	3 1/16	20	11 1/2	6	30"HEX	2,495	48	675	FR1000-6-10	
		10'-11 3/4"	8	12 3/4	4 1/4	3 1/16	20	11 1/2	6	30"HEX	3,545	48	735	FR1000-8-10	
		11'-2 1/8"	10	12 3/4	4 1/4	3 1/16	20	11 1/2	6	30"HEX	4,750	48	820	FR1000-10-10	
		11'-5 3/4"	12	12 3/4	4 1/4	3 1/16	20	11 1/2	6	30"HEX	5,935	48	900	FR1000-12-10	
		11'-8 3/4"	14	12 3/4	4 1/4	4 1/8	20	11 1/2	6	30"HEX	6,007	48	1068	FR1000-14-10	
		11'-8 3/4"	16	12 3/4	4 1/4	4 1/8	20	11 1/2	6	30"HEX	6,958	48	1139	FR1000-16-10	
		12'-11 3/4"	4	12 3/4	4 1/4	3 1/16	20	11 1/2	6	30"HEX	1,420	48	705	FR1000-4-12	
		12'-11 3/4"	6	12 3/4	4 1/4	3 1/16	20	11 1/2	6	30"HEX	2,495	48	745	FR1000-6-12	
		12'-11 3/4"	8	12 3/4	4 1/4	3 1/16	20	11 1/2	6	30"HEX	3,545	48	800	FR1000-8-12	
		13'-2 1/8"	10	12 3/4	4 1/4	3 1/16	20	11 1/2	6	30"HEX	4,750	48	890	FR1000-10-12	
		13'-5 3/4"	12	12 3/4	4 1/4	3 1/16	20	11 1/2	6	30"HEX	5,935	48	965	FR1000-12-12	
	13'-8 3/4"	14	12 3/4	4 1/4	4 1/8	20	11 1/2	6	30"HEX	6,007	48	1147	FR1000-14-12		
	13'-8 3/4"	16	12 3/4	4 1/4	4 1/8	20	11 1/2	6	30"HEX	6,958	48	1218	FR1000-16-12		



Spanco, Inc.
604 Hemlock Road
Morgantown, PA, 19543

Toll Free: 800-869-2080
Local: 610-286-7200
Fax: 610-286-0085

Spanco.com

TEN-YEAR SPANCO WARRANTY

Products covered under the Ten-Year Warranty:

- Manual Steel Freestanding, Ceiling Mounted Workstation Bridge Cranes, and Monorails
- Manual Aluminum (Alu-Track®) Workstation Bridge Cranes and Monorails
- Manual Jib Cranes (I-Beam, Articulating, and Workstation Jib Cranes)
- Manual Gantry Cranes and Tripods

What the Ten-Year Warranty covers:

- Defects in Equipment material and workmanship
- Wearable parts (end truck and hoist trolley wheels only)

Spanco, Inc. warrants its manual workstation bridge crane products, jib crane products, and gantry crane products to be free from defects in material and workmanship for a period of ten (10) years or 20,000 hours, commencing on the date of shipment to the first retail purchaser. This warranty extends to non-wearable parts only, with the exception of the wheels supplied on manually operated workstation end trucks and hoist trolleys. This warranty does not cover defective equipment or system failure caused by misuse, negligence, improper installation or maintenance, or equipment that has been used in excess of its rated capacity or beyond its service factors. It does not apply to equipment that has been altered without Spanco's written authorization.

Written notice of any claimed system defect must be given to Spanco within thirty days of discovery. Spanco's obligation under this warranty is limited to the replacement or repair of Spanco's products at the factory or separate location approved by Spanco. The purchaser is responsible for all freight and transportation costs relating to equipment repair or replacement. **Other than the abovementioned warranty, Spanco will not honor any other warranties—whether express, implied, or statutory—and disclaims any warranties of merchantability or fitness for a particular purpose. Spanco is not liable—under any circumstances—for any indirect, incidental, or consequential damages including but not limited to lost profits, increased operating costs, or loss of production.**

This warranty does not extend to components or accessories not manufactured by Spanco. The purchaser's remedy for such components and accessories will be determined by the terms and conditions of any the warranty provided by the manufacturer of such components and accessories.

NOTE: *All motorized Spanco products come with a One-Year Warranty on drive components.*